

## 2000nm High Power Isolator (HPIS / HPMIS)

### Features

- Wide Operating Wavelength
- High Isolation & High PER
- Telcordia GR-1221 Compliant
- Available for Both Axes Pass or Fast Axis Block

### Application

- Fiber Laser
- Surgical Equipment
- Gas Sensor System



### Specifications

Parameters	Unit	Single Stage	Dual Stage
Center Wavelength	nm	2000	
Peak isolation	dB	30	45
Min Isolation ( $\lambda c \pm 15\text{nm}, 23^\circ\text{C}$ )	dB	20	35
Typ. IL ( $\lambda c \pm 20\text{nm}, 23^\circ\text{C}$ )	dB	0.80	1.00
Insertion Loss ( $\lambda c \pm 20\text{nm}, -5 \sim +70^\circ\text{C}$ )	dB	$\leq 1.5$	$\leq 1.80$
Polarization Dependent Loss (PDL) (for SMF)	dB	$\leq 0.05$	$\leq 0.10$
PER (for PMF)	Both Axes Pass	dB $\geq 20$	
	Fast Axis Blocked	dB $\geq 23$	
Return Loss (Input / Output) (RL)	dB	$\geq 50/50$	$\geq 50/50$
Fiber Type		SMF-28e, SM1950, PM1550, PM1950, PM2000,	
Max Power Handling CW	W	1, 2, 3, 5, 10, 20	
Operating Temperature	$^\circ\text{C}$	$-0 \sim +75$	
Storage Temperature	$^\circ\text{C}$	$-40 \sim +85$	

Above data test at room temperature without connectors. With connectors, IL+0.3dB, RL-5dB, PER-2dB.

Optical Power 1W only after connector added.

Default connector key is aligned to slow axis.

Default FC connector key width 2.02mm (narrow key), 2.12mm (wide key) available on request.

### Typical Spectrum

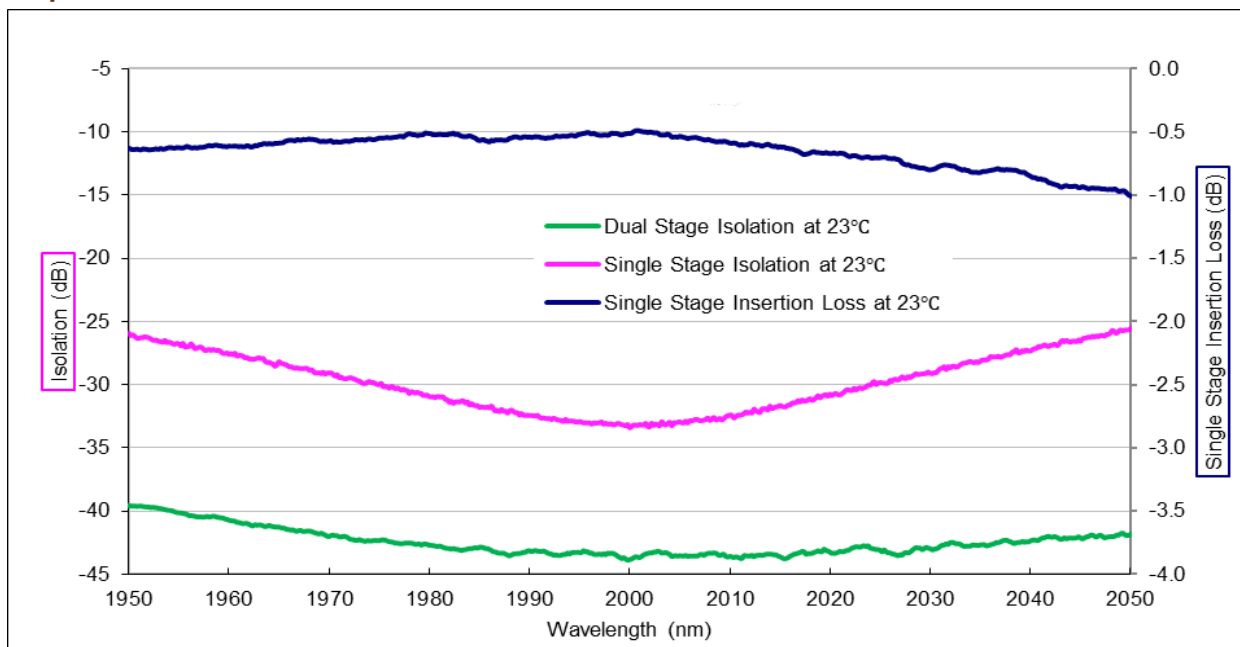

### Package Information

Fiber Length	1m, others on request		
Pigtail Type	250 $\mu\text{m}$ Bare Fiber	900 $\mu\text{m}$ Loose Tube	2mm/3mm Loose Cable
Dimensions(mm)	$\phi 5.5 \times 35, 80 \times 12 \times 10$	$\phi 5.5 \times 35, 80 \times 12 \times 10$	90x16x9
Approx Weight (g)	35	50	65

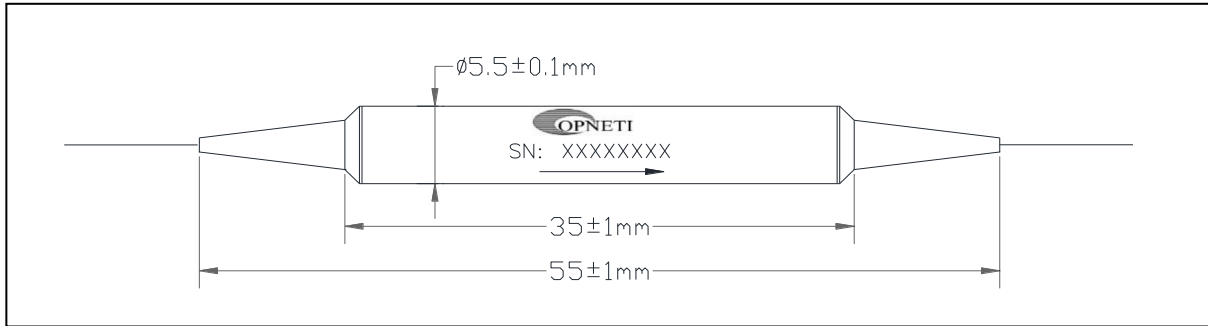

for 1~5 W

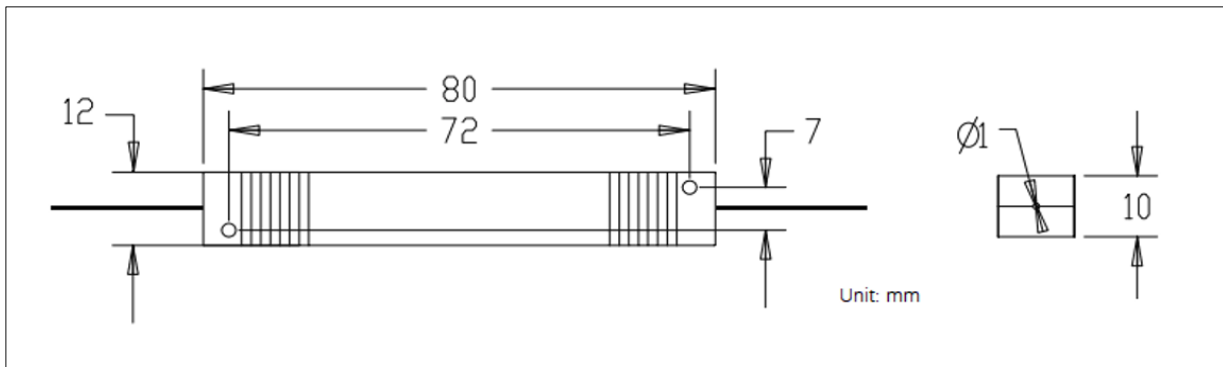

for 6~20W

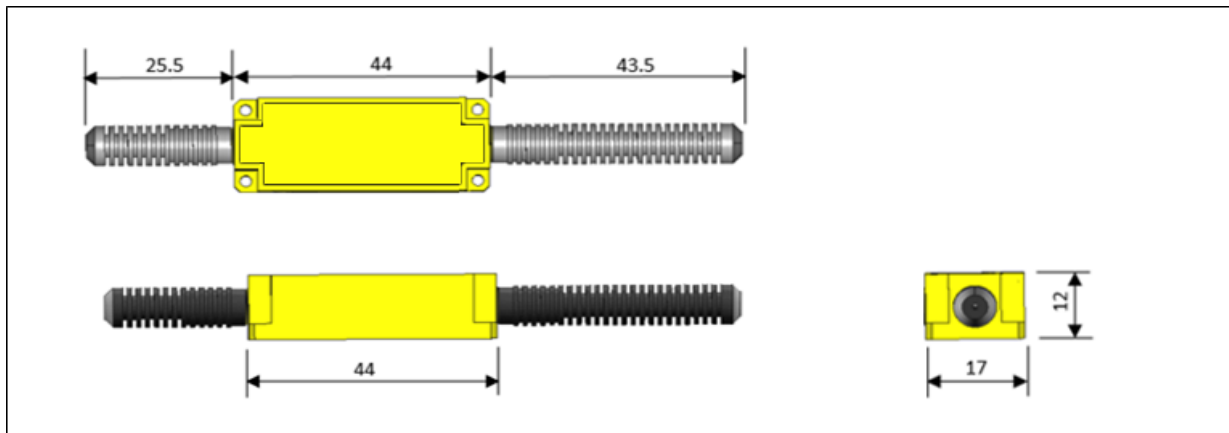

for 11~20W

### Ordering Information

HPIS- ①-②②②②-③-④④④-⑤-⑥-⑦⑦-⑧⑧⑧⑧⑧⑧-⑨⑨  
 HPMIS-

①	Type	S=Single Stage; D=Dual Stage;
②	Wavelength	2000;
③	Axis Alignment	F=Fast Axis Blocked; B=Both Axes Working;
④	Pigtail Type	250=250μm Fiber; 900=900μm Loose Tube; 2000=2mm Loose Cable; 3000=3mm Loose Cable;
⑤	Fiber Type	1=SMF-28e; S9=SM1950; P15=PM1550; P19=PM1950; P20=PM2000;
⑥	Fiber Length	1=1m; XX=other;
⑦	Connector	NE=None; FA=FC/APC; FC=FC/UPC; SA=SC/APC; SC=SC/UPC; LC=LC/UPC; XX=Others;
⑧	Package size	5.5x35; 80x12x10;
⑨	Power Handling	1W; 2W; 3W; 5W; 10W; 20W